

# **The Design of Online Monitoring System of Low-Voltage Switch Cabinet**

Wang Wei-guang<sup>1</sup>, CHENG Wu-shan<sup>2</sup>

<sup>1,2</sup> (College of Mechanical Engineering, Shanghai University of Engineering Science, Shanghai 201620, P.R.China)

**ABSTRACT** :In view of the limitation of low-voltage switch cabinet status detection, this paper designed a new type of online monitoring system for low voltage switchgear. Quasi using weak magnetic sensor to replace the traditional electromagnetic transformer acquisition bus current, and proposed based on ARM core embedded operating system, to achieve low-voltage switch cabinet of voltage, current and switching state parameters on-line monitoring and real-time display. The electromagnetic compatibility design of the system software and hardware and the design of the line of the weak current signal are presented. The system realized on switch cabinet integration testing, monitoring and control, improve the reliability of the system and integration, reduce the maintenance cost, to enhance the intelligent switchgear level and distribution network, safe and stable operation.

**Keywords:** *low-voltage switch cabinet, ARM embedded system, on line monitoring*

## **I. INTRODUCTION**

Low-voltage switch cabinet as the electrical energy node devices of transmission and distribution, in the power system plays a very important role, and the safety and stability of operation in order to adapt to the modern power system, and development trend of modern industrial production and social life. As one of the main forms of the smart grid user terminal, low-voltage switch cabinet gradually to digital, integrated, intelligent and networked. The theoretical research and product development of intelligent low voltage switchgear online monitoring system has become a hot research topic at home and abroad.

## **II. OVERVIEW OF THE ON LINE MONITORING SYSTEM FOR LOW VOLTAGE SWITCHGEAR**

The online monitoring system of low-voltage switch cabinet needs to complete the function includes: voltage and current through the magnetic sensor to measure busbar voltage and current, and the voltage and current signals measured are filtered; synchronous acquisition through high-speed multi-channel AD converter with voltage and current signal of multiple channels, and the collected data in real time sent to the main control unit; the main control unit of a digital signal receiver acquisition of voltage and current, and data storage and computing; on the other hand to collect the switch signal, and according to the calculation results to determine the on-off control field unit, the voltage and current signals, switch signals and signal processing are uploaded to the site PC waveform data display, trend analysis and fault record.

## **III. HARDWARE DESIGN OF ONLINE MONITORING SYSTEM FOR LOW-VOLTAGE SWITCH CABINET**

### **3.1 Overall hardware design of the system**

By the energy parameter data of the local storage and establish communication with the host computer,

monitoring system hardware structure as shown in Figure 2-1 is the hardware structure of the online monitoring system of low-voltage switch cabinet based on ARM9 s3c2440a chip as the core, mainly to complete the sensor signal acquisition, waveform data of the online real time display, power. Intends to the weak magnetic sensor instead of traditional ferromagnetic type current transformer measurement of electric current of low-voltage switch cabinet and monitoring system including opening and closing and tripping field signals, switch signals.

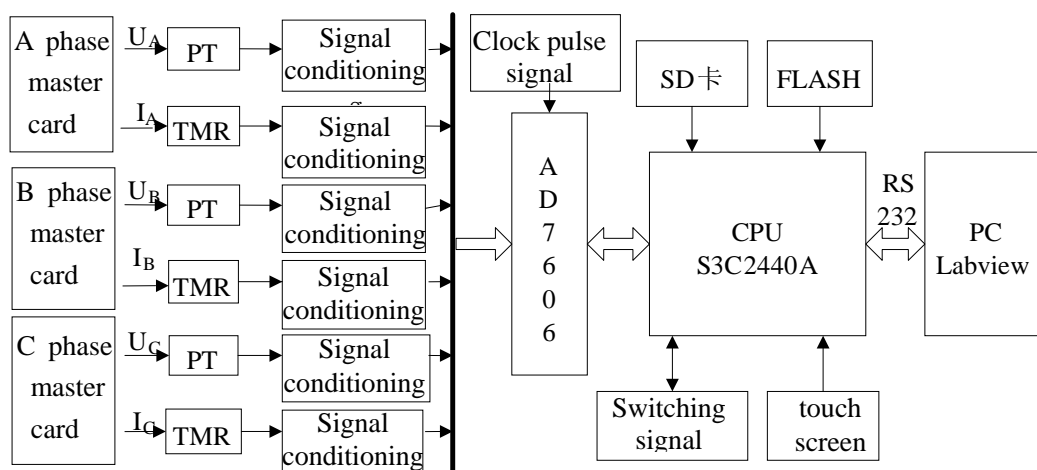

Fig.3-1 Hardware structure of the online monitoring system for low-voltage switch cabinet

### 3.2 Magnetic sensor current measuring node circuit

A magnetic sensor current measuring node circuit comprises a power supply circuit and a signal processing circuit of the magnetic sensor. In the design, two kinds of signal output modes are used in the design of the system. The power supply circuit and the signal output circuit of the magnetic sensor are shown in Figure 2-2.

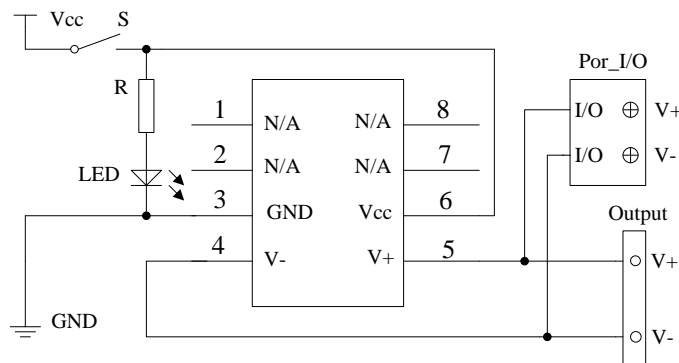

Fig.3-2 TMR magnetic sensor power supply circuit and signal output circuit

### 3.3 Design of analog to digital conversion module

The analog-to-digital converter is an important part of the online monitoring system of low-voltage switch cabinet, its performance is directly related to the accuracy and the real-time performance of the whole system. Due to the electrical signals for the three-phase signal, the design need of three-phase voltage and three-phase current six channel electrical parameter signal monitoring, in order to avoid the phase difference of voltage and current in the acquisition of dislocation data and deal with 6 channel signal of synchronous sampling. It also needs to consider the sampling precision and sampling rate of adc. Based on the above requirements, AD7606 ADC synchronous sampling by using ADI system. The use of SPI serial bus communication between the AD7606 and the main control unit of S3C2440A. The design of the interface as shown in Figure 2-3 and AD7606 S3C2440A. Between S3C2440A and SPI through the AD7606 bus communication, set up S3C2440A based devices, providing SPI data transmission clock SCLK. In the process of data transmission, the main control unit S3C2440A only need to read data from the AD7606, so the MOSI of the SPI port will be suspended.

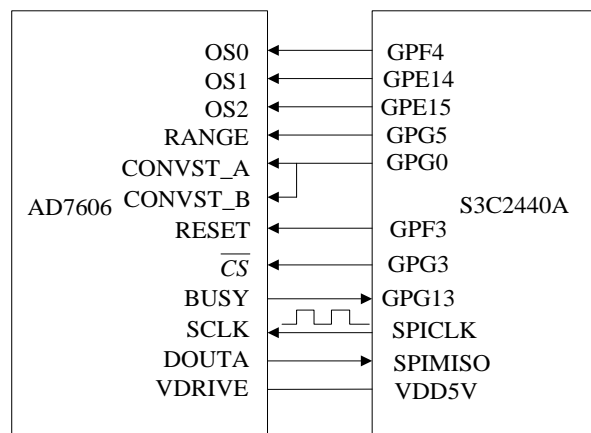

Fig.3-3 Schematic diagram of interface between AD7606 and S3C2440A

### 3.4 signal processing circuit

Due to the influence of the sensor itself and the circuit on the board, the sensor output signal contains complex high frequency noise signal. Before sampling the sampling circuit, the output signal of the sensor should be filtered and processed. The voltage controlled voltage source low pass filter circuit with excellent performance in low frequency range filter is adopted to realize the noise reduction processing of the output signal of the sensor, and the stability and reliability of the output signal is enhanced. Voltage controlled voltage source low pass filter circuit as shown in figure 2-4.

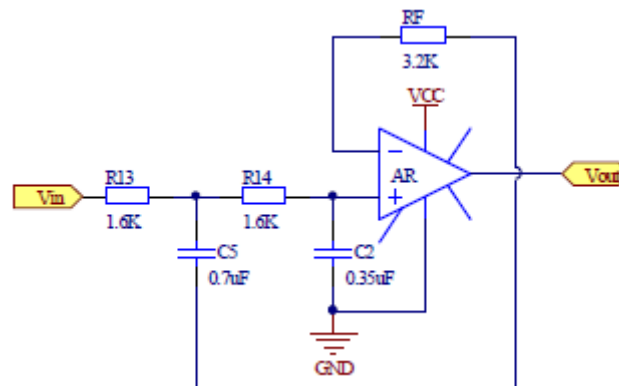

Fig.3-4 Voltage controlled voltage source low-pass filter circuit schematic

### 3.5 ARM development board design

Every need, from the whole function of the system and function modules of shape, design and development of the ARM9 development board based on S3C2440A. For the secondary development and expansion of system is convenient, in the designing of development board will ad7606 module and arm development board separate design, and are connected through an external interface, the actual use only combined to complete the system of building.

ARM development board mainly includes two parts: the core board and the bottom board. Core plate and a bottom plate through a connector connected with this design method has the advantages of, if need to change the circuit or extend to the mouth of the functions of the system, then only need to redesign the can to the floor, thereby reducing the cost. Core board circuit design part mainly includes the design of core board power supply circuit, SDRAM, NAND flash and NOR flash circuit; circuit board design mainly includes the motherboard power supply circuit, the minimum system circuit, RS232 communication circuit and USB circuit design.

#### IV. SOFTWARE DESIGN

The main task of software design is to use assembly language and C language program to realize the expected functions, including software structure design and software program design. The design of the software part adopts modular design method, according to the monitoring unit is expected to achieve the function, the design of system software mainly by the initialization program, data acquisition program, communication program, various record program and main program part. In addition, the protection algorithm is optimized to improve the speed of fault judgment, and at the same time, it should take into account the reliability of the power supply system.

In the arm on the transplant of embedded operating system, mainly for the site data display, data storage and communication is established through the RS232 and remote PC, complete monitoring system of multi task scheduling, embedded system software structure as shown in Figure 3-1. In order to facilitate software development and later the function expansion and maintenance, software uses the modular design thought, can be very flexible and the realization of the system function of adjustment, the structure of such a system has strong real-time performance and stability.

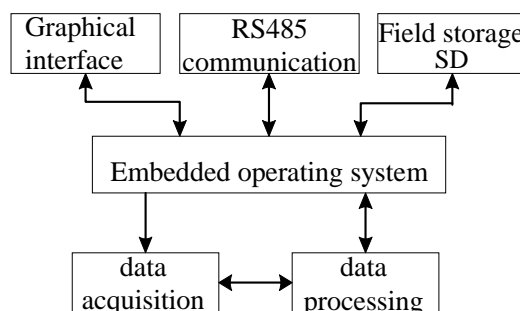

Fig.4-1 Software overall structure of monitoring system

#### V. EXPERIMENTAL DEMONSTRATION

##### 5.1 Repeatability analysis

The data of the 5 measurement samples were analyzed by the data of 5 repeated experiments, and the consistency of the results obtained by repeated measurements under the same measuring condition was studied. Through the analysis we can know that under the same conditions, the repeatability of the 5 repeated experiments can be up to 0.06%, the maximum is not more than 0.5%, the convergence of the experimental data is good, and the consistency of the experimental data is good. Therefore, in the linear range of the output of the sensor, the repeatability of the 5 repeat experiment is better. As can be seen, in the presence of the phase of the electromagnetic interference, the output of the TMR magnetic sensor is stable, and the output result is reliable.

##### 5.2 Error analysis of voltage measurement

Through the experimental data analysis can be drawn, online monitoring system of low-voltage switch cabinet in the measurement process of three-phase voltage, measure the maximum relative error is 0.58%, measuring the minimum relative error - 0.17%, voltage measurement error control in a smaller range, realize the three phase voltage of accurate monitoring, achieve the system voltage measurement error is less than 1.5% of the design standards.

##### 5.3 Error analysis of current measurement

Through the experimental data analysis can be drawn, low-voltage switch cabinet on-line monitoring system for current measurement of the maximum relative error less than 1.8%, the minimum relative error can reach 0.5%, which can be drawn, the monitoring system can realize the accurate monitoring of low-voltage switch

cabinet three-phase current parameters and higher measurement precision of the TMR magnetic sensor to measurement error of the current system from 0.5% to 2.3% in the standard.

## **VI. CONCLUSION**

In this paper, the requirement of low voltage switchgear in smart grid environment is studied and developed, and the online monitoring system of low voltage switchgear is studied and developed. Proposed on the magnetic sensors as measuring sensor of switch cabinet bus current to replace the conventional current transformer, and to ARM9/S3C2440A as the core of the main control chip, establish a real-time dynamic response of intelligent monitoring system, effectively realized real-time operating state of low-voltage switch cabinet of dynamic monitoring and fault judgment, under the smart grid environment the development of high voltage switch cabinet to a certain role in promoting. With the continuous promotion of intelligent switch cabinet, switch cabinet intelligent monitoring system is bound to be widely used in the field of variable power distribution.

## **REFERENCE**

- [1]. Li Yong. Design of intelligent monitoring unit for low voltage power distribution switch cabinet [D]. Chengdu University of Technology, 2010
- [2]. Cheng Wushan. Research on Intelligent Testing Technology of low voltage electrical apparatus [J]. low-voltage electrical appliances, 2010,21:41-45.
- [3]. Meng Yanqing, Zhao Hongwei, Zou Yulin. Research on intelligent monitoring device of switch cabinet based on [J]. ARM high voltage apparatus, 2014,03:29-35+43.
- [4]. Li Zhenzhen. Intelligent switch cabinet in the distribution system of online monitoring and fault diagnosis of [D]. Hebei University of Engineering, 2014
- [5]. Chi Yan, LvYuanyuan, JiaHongwei, Cui Xiaomei. The product design of the intelligent monitoring system for low voltage power distribution [J]. Journal of Jimei University (NATURAL SCIENCE EDITION), 2004,02:138-142.
- [6]. Gabriele D'Antona , "Processing Magnetic Sensor Array Data for AC Current Measurement in Multiconductor Systems", IEEE transactions on instrumentation and measurement, VOL. 50, NO. 5, October 2001